

## Type and Application

Temperature resistant big hole puncher shaped charge with steel case, thread and detonating cord holder for use with through tubing strip gun systems for oilfield applications.

Explosive Content = 9g

Recommended Tubing Wall Thickness: 6.5mm to 10mm

## Performance

Average hole size in 6.5mm wall thickness is 24mm without damage to casing in 35mm distance.

## Pressure Rating

100 MPa / 14,500 psi

## Debris / Charge

62g / 2.19oz

## Shelf Life

5 years at storage condition: -40°C to +60°C, -40°F to +140°F; maximum 65 % relative humidity, good ventilation.

## Disposal

Shaped charges should be destroyed only by authorised persons and in accordance with all applicable laws, regulations and company procedures.

## Specifications

Type	Part Number	Classification	CE Number	UN Number	D.O.T.
<b>RDX</b>	<b>2317070</b>	1.4S	0080.EXP.06.0014	0441	EX200602068
<b>HMX</b>	<b>2317071</b>	1.4S	0080.EXP.06.0014	0441	EX200602068
<b>HNS</b>	<b>On request</b>	1.4S	0080.EXP.06.0014	0441	EX200602068

## Temperature Resistance

Type	Time	Temperature in °C	Temperature in °F
<b>RDX</b>	1 hour	165°C	330°F
<b>HMX</b>	1 hour	205°C	400°F
<b>HNS</b>	1 hour	260°C	500°F

## Strip Gun Configuration

Gun Size		Shot Density		Phasing
1 11/16"	43 mm	4 spf	13 spm	0°
1 11/16"	43 mm	6 spf	20 spm	0°

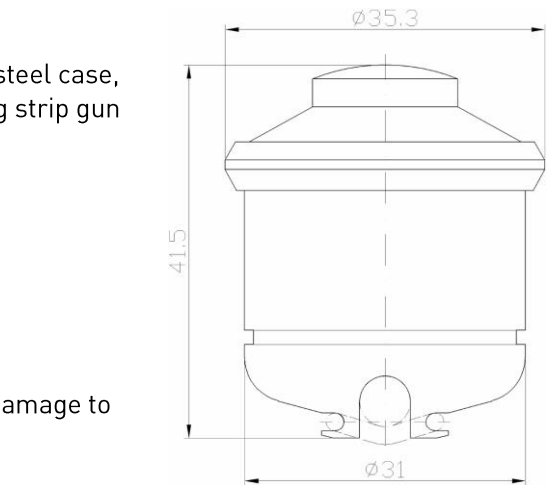

All Dimensions in

## Packing Information

Quantity per box	50 pcs
Gross weight per box	8.7 kg
Net weight per box	6.5 kg
NEC per box	0.45 kg
Dimensions of box	40cm x 40cm x 16cm
Product Weight	130 g
Package Type	Carton + Vacuum Bag